

# A Novel Three Phase Multi-String Multilevel Inverter Topology with DERs Applied to Induction Machine Drive

D.Goutham Krishna<sup>1</sup>

T.Raghu<sup>2</sup>

S.ChandraSekhar<sup>3</sup>

<sup>1</sup>M.tech Scholar (EPS), Anurag Engineering College, Kodad, Telangana, India

<sup>2</sup>Associate Professor (EEE), Anurag Engineering College, Kodad, Telangana, India

<sup>3</sup>Associate Professor & HOD (EEE), Anurag Engineering College, Kodad, Telangana, India

**Abstract-** Multilevel voltage source converters are emerging as a new breed of power converter options for high-power applications. The multilevel voltage source converters typically synthesize the staircase voltage wave from several levels of dc capacitor voltages. One of the major limitations of the multilevel Converters is the voltage unbalance between different levels. The techniques to balance the voltage between different levels normally involve voltage clamping or capacitor charge control. There are several ways of implementing voltage balance in multilevel converters. This paper presents a three-phase multistring multilevel inverter coupled to induction machine drive for evaluating the performance characteristics of drive application. The multilevel topology consists of several H-bridge cells connected in series, each one connected to a string. The simplified multilevel inverter requires only six active switches instead of the eight required in the conventional cascaded H-bridge multilevel inverter. In addition, two active switches are operated at the line frequency. The studied multistring inverter topology offers strong advantages such as improved output waveforms, smaller filter size, and lower electromagnetic interference and total harmonics distortion. Finally an asymmetrical configuration is proposed with this we are getting seven levels with six switches.

**Index Terms**—DC/AC power conversion, multilevel inverter, induction machine drive

## I. INTRODUCTION

Numerous industrial applications have begun to require higher power apparatus in recent years. Some medium voltage motor drives and utility applications require medium voltage and megawatt power level. For a medium voltage grid, it is troublesome to connect only one power semiconductor switch directly. As a result, a multilevel power converter structure has been introduced as an alternative in high power and medium voltage situations. A multilevel converter not only achieves high power ratings, but also enables the use of renewable energy sources and drive applications. With the advancement of power electronics and emergence of new multilevel

converter topologies, it is possible to work at voltage levels beyond the classic semiconductor limits. The multilevel converters achieve high-voltage switching by means of a series of voltage steps, each of which lies within the ratings of the individual power devices. Among the multilevel Converters, the cascaded H-bridge topology (CHB) is particularly attractive in high-voltage applications, because it requires the least number of components to synthesize the same number of voltage levels.

These converter topologies can generate high-quality voltage waveforms with power semiconductor switches operating at a frequency near the fundamental. Although, in low-power applications, the switching frequency of the power switches is not restricted, a low switching frequency can increase the efficiency of the converter. Additionally, multilevel converters feature several dc links, making possible the independent voltage controls.

A single-phase multistring five-level inverter integrated with an auxiliary circuit was recently proposed for dc/ac power conversion. This topology used in the power stage offers an important improvement in terms of lower component count and reduced output harmonics. Unfortunately, high switching losses in the additional auxiliary circuit caused the efficiency of the multistring five-level inverter to be approximately 4% less than that of the conventional multistring three-level inverter, a novel isolated single-phase inverter with generalized zero vectors (GZV) modulation scheme was first presented to simplify the configuration. However, this circuit can still only operate in a limited voltage range for practical applications and suffer degradation in the overall efficiency as the duty cycle of the dc-side switch of the front-end conventional boost converter approaches unity. Furthermore, the use of isolated transformer with multi windings of the GZV based inverter results in the larger size, weight, and additional expense. The newly constructed

inverter topology offer strong advantages such as improved output waveforms, smaller filter size, and lower EMI and total harmonics distortion (THD). In this letter, the operating principle of the developed system is described, and a prototype is constructed for verifying the effectiveness of the topology.

II. SYSTEM CONFIGURATION OF OPERATION PRINCIPLES

A general overview of different types of inverters modules is given. This letter presents a multi string multilevel inverter for DERs application. The multi string inverter shown in Fig. 1 is a further development of the string.

Inverter, whereby several strings are interfaced with their own dc/dc converter to a common inverter. This centralized system is beneficial because each string can be controlled individually. Further enlargements are easily achieved because a new string with a dc/dc converter can be plugged into the existing platform, enabling a flexible design with high efficiency. The single-phase multi string multilevel inverter topology used in this study is shown in Fig. 1

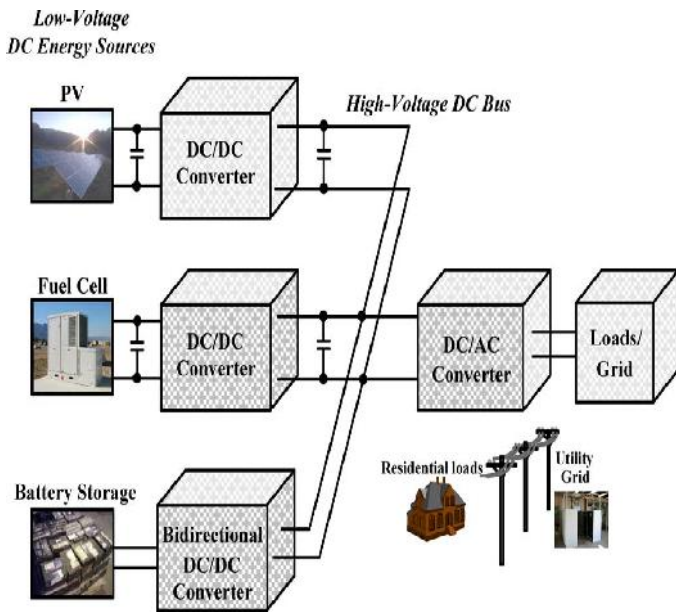

Fig.1 Microgrid system

This topology configuration consists of two high step-up dc/dc converters connected to their individual dc-bus capacitor and a simplified multilevel inverter. Input sources, DER module 1, and DER module 2 are connected to the inverter followed a linear resistive load through the high step-up dc/dc converters. The studied simplified five-level inverter is used instead of a conventional cascaded pulse width-modulated (PWM) inverter because it offers strong advantages such as improved output waveforms, smaller filter size, and lower EMI and THD. It should be noted that, by using the independent voltage

regulation control of the individual high step-up converter, voltage balance control for the two bus capacitors Cbus1, Cbus2 can be achieved naturally.

A Full H-Bridge

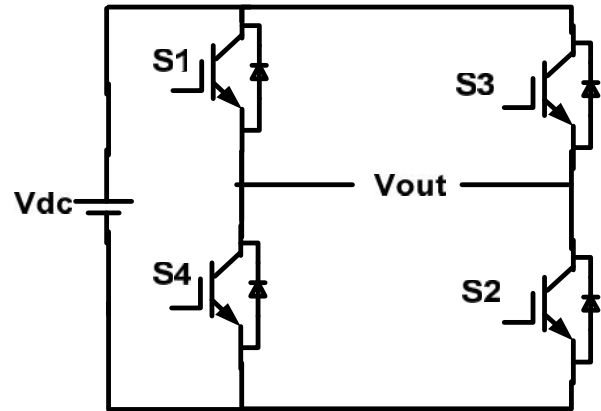

Figure. 2 Full H-Bridge

Fig.2 shows the Full H-Bridge Configuration. By using single H-Bridge we can get 3 voltage levels. The number output voltage levels of cascaded Full H-Bridge are given by  $2n+1$  and voltage step of each level is given by  $V_{dc}/n$ . Where  $n$  is number of H-bridges connected in cascaded. The switching table is given in Table 1.

Table 1. Switching table for Full H-Bridge

Switches Turn ON	Voltage Level
S1,S2	$V_{dc}$
S3,S4	$-V_{dc}$
S4,D2	0

B. Simplified Multilevel Inverter Stage

A new single-phase multi string topology, presented as a new basic circuitry in Fig. 3. Referring to Fig. 2, it should be assumed that, in this configuration, the two capacitors in the capacitive voltage divider are connected directly across the dc bus, and all switching combinations are activated in an output cycle. The dynamic voltage balance between the two capacitors is automatically controlled by the preceding high step-up converter stage. Then, we can

$$\text{Assume } V_{s1} = V_{s2} = V_s$$

This topology includes six power switches—two fewer than the CCHB inverter with eight power switches—which drastically reduces the power circuit complexity and simplifies modulator circuit design and implementation. The phase

disposition (PD) PWM control scheme is introduced to generate switching signals and to produce five output-voltage levels: 0,  $V_s$ ,  $2V_s$ ,  $-V_s$ , and  $-2V_s$ .

This inverter topology uses two carrier signals and one reference to generate PWM signals for the switches. The modulation strategy and its implemented logic scheme in Fig. 4(a) and (b) are a widely used alternative for PD modulation. With the exception of an offset value equivalent to the carrier signal amplitude, two comparators are used in this scheme with identical carrier signals  $V_{tri1}$  and  $V_{tri2}$  to provide high-frequency switching signals for switches  $S_{a1}$ ,  $S_{b1}$ ,  $S_{a3}$ , and  $S_{b3}$ . Another comparator is used for zero-crossing detection to provide line-frequency switching signals for switches  $S_{a2}$  and  $S_{b2}$ .

The required five output levels and the corresponding operation modes of the multi level inverter stage are described clearly as follows.

- 1) Maximum positive output,  $2V_s$  : Active switches  $S_{a2}$ ,  $S_{b1}$ , and  $S_{b3}$  are ON; the voltage applied to the LC output filter is  $2V_s$ .
- 2) Half-level positive output,  $+V_s$  : This output condition can be induced by two different switching combinations. One switching combination is such that active switches  $S_{a2}$ ,  $S_{b1}$ , and  $S_{a3}$  are ON; the other is such that active switches  $S_{a2}$ ,  $S_{a1}$ , and  $S_{b3}$  are ON. During this operating stage, the voltage applied to the LC output filter is  $+V_s$ .
- 3) Zero output, 0: This output condition can be formed by either of the two switching structures. Once the left or right switching leg is ON, the load will be short-circuited, and the voltage applied to the load terminals

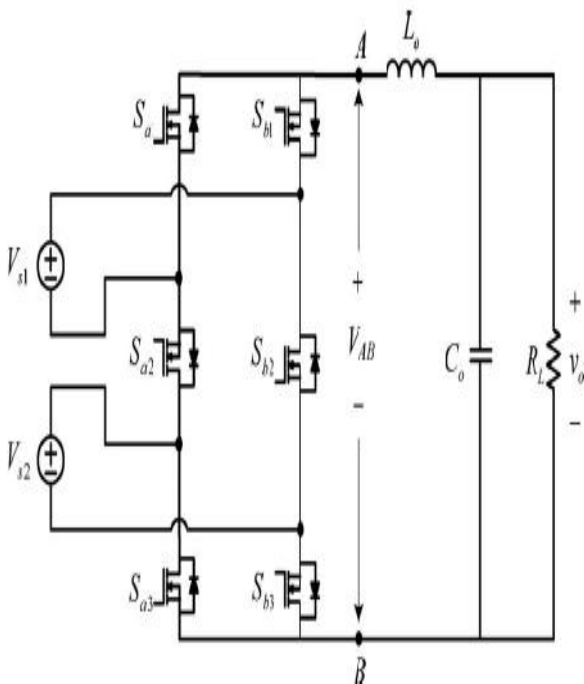

Figure. 3 Basic five-level inverter circuitry

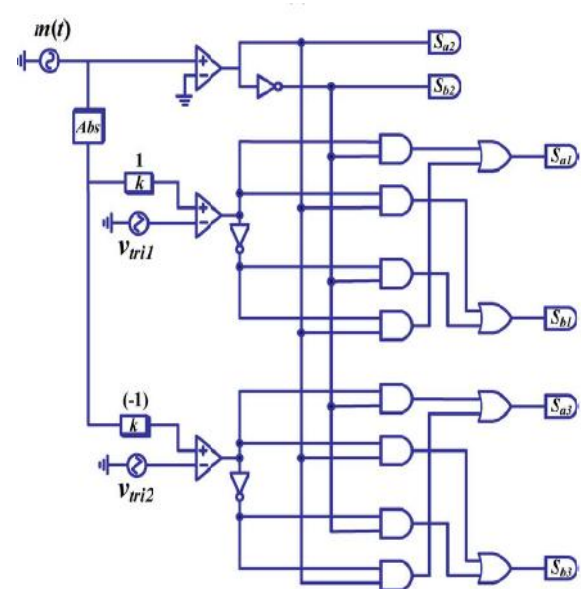

Figure.4 modulation logic

- 4) Half-level negative output,  $-V_s$  : This output condition can be induced by either of the two different switching combinations. One switching combination is such that active switches  $S_{a1}$ ,  $S_{b2}$ , and  $S_{b3}$  are ON; the other is such that active switches  $S_{a3}$ ,  $S_{b1}$ , and  $S_{b2}$  are ON.
- 5) Maximum negative output,  $-2V_s$  : During this stage, active switches  $S_{a1}$ ,  $S_{a3}$ , and  $S_{b2}$  are ON, and the voltage applied to the LC output filter is  $-2V_s$ .

### III. MATLAB/SIMULINK MODEL & SIMULATION RESULTS

Here the simulation is carried out in two cases 1. A Five Level Single phase multi-string multilevel inverter 2. A Five Level Three phase multi-string multilevel inverter applied to induction machine drive.

Case 1: A Five Level Single phase multi-string multilevel inverter:

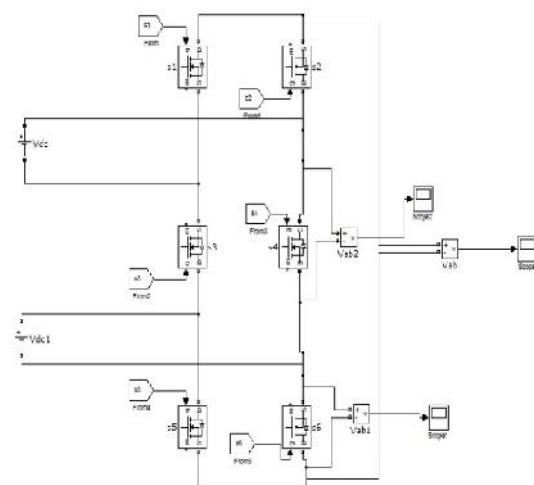

Figure.5 Matlab/Simulink model of single phase multi-string multilevel inverter

The basic simulation circuit, Figure.5 is a multi string inverter with combination of six switches. Based on the selection of switches in the circuit output voltage are obtained.

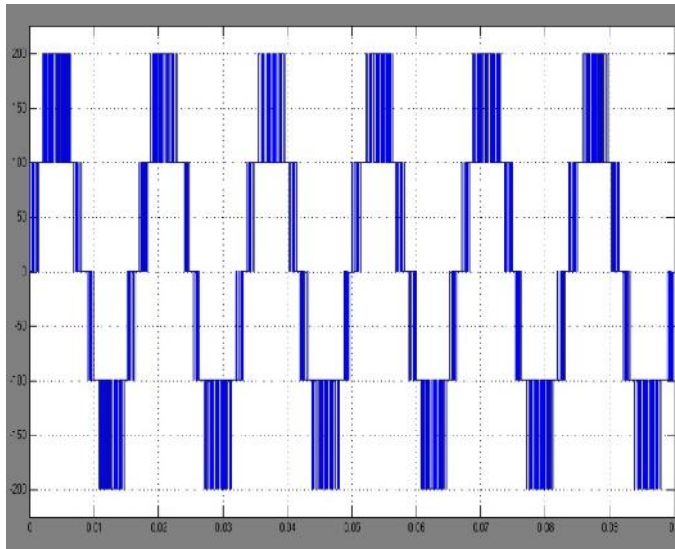

Figure.6 Output voltage waveform of 5 level multi sting inverter using PWM

Figure.6 shows the output voltages which are obtained by the multi string inverter of 5 level using PWM

Case 2: A Five Level Three phase multi-string multilevel inverter applied to induction machine drive

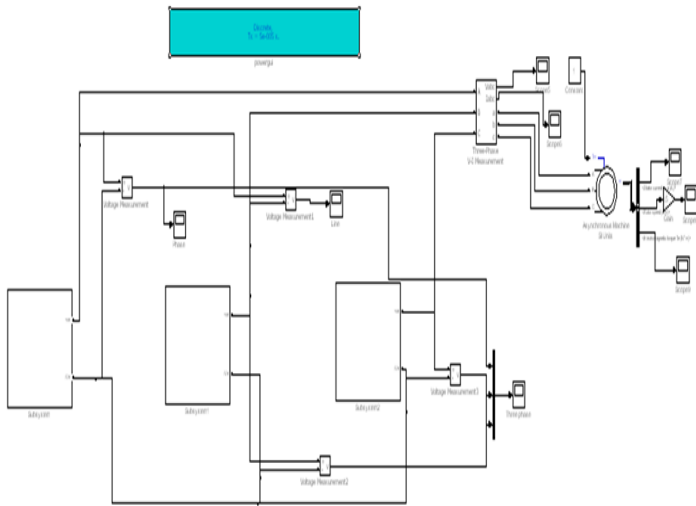

Figure.7 Matlab/Simulink model of single phase multi-string multilevel inverter

Figure 7 shows the Matlab/Simulink model of single phase multi-string multilevel inverter

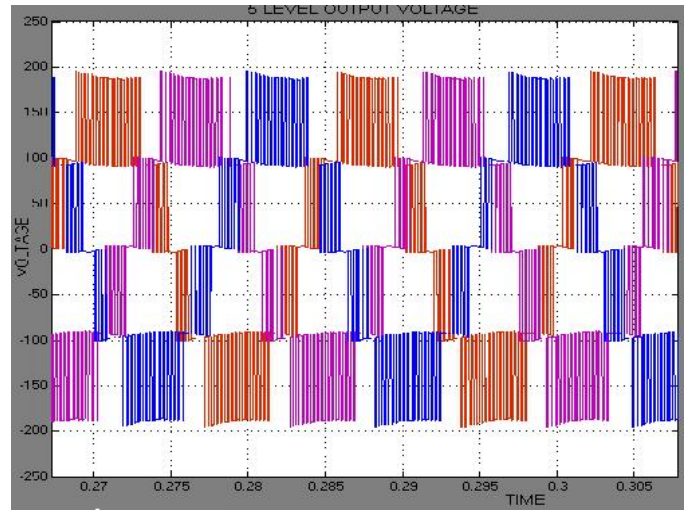

Figure 8: Output voltage waveform of three phase 5 level multi sting inverter using PWM

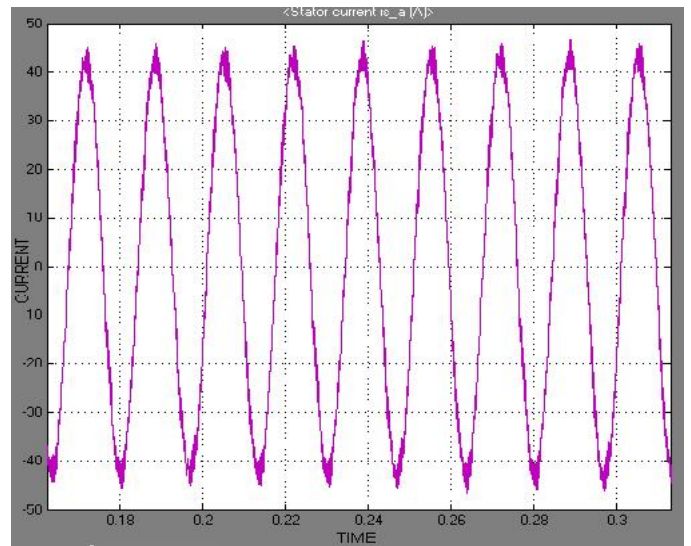

Figure 9: Stator current of induction machine drive

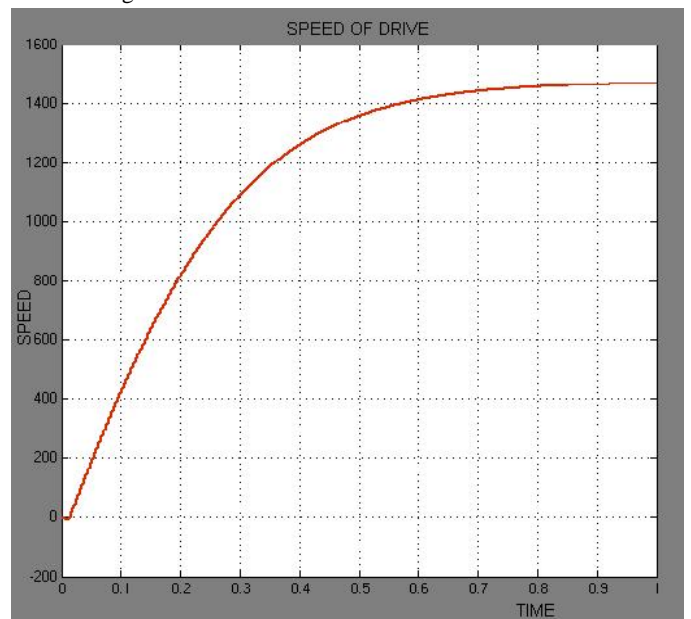

Figure 10: Speed of the drive

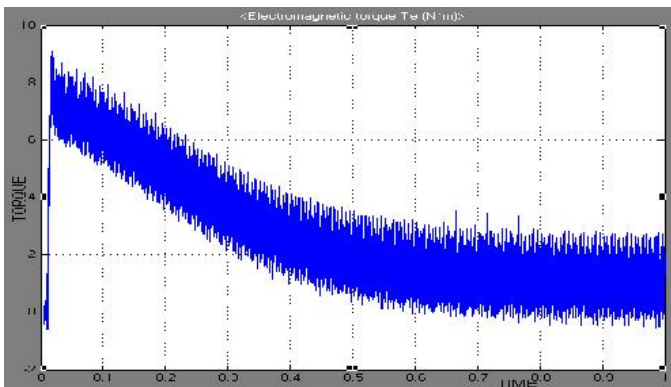

Figure 11: Electromagnetic torque of drive

Figure 9, 10, 11 shows the stator current, speed, electromagnetic torque respectively of the induction machine drive

#### IV. CONCLUSION

This paper presents a five level single-phase multistring multilevel converter and three phase multistring multilevel inverter applied to induction machine drive. The multilevel topology consists of several H-bridge cells connected in series, each one connected to a string. Finally a novel three phase multistring multilevel inverter applied to induction machine drive. The proposed converter produces more voltage levels with less number of switches compared to H- bridge configuration. This will reduce number of gate drivers and protection circuits which in turn reduces the cost and complexity of the circuit. Finally a three phase model with induction machine drive of the proposed circuit is shown for evaluating the drive performance and simulation results are presented.

#### REFERENCES

- [1] Y. Li, D.M. Vilathgamuwa, and P.C. Loh, "Design, analysis, and realtime testing of a controller for multibus microgrid system," IEEE Trans Electron., vol. 19, no. 5, pp. 1195-1204, Sep. 2004.
- [2] N. Hatzigiorgi, H. Asano, R. Iravani, and C. Marnay, "Microgrids," IEEE power Energy Mag., vol. 5, no. 4, pp.78-94, Jul/Aug.2007.
- [3] F. Katiraei, R. Iravani, N. Hatzigiorgi, and A. Dimeas, "Microgrids management," IEEE Power Energy Mag., vol. 6, no. 3, pp. 54-65, May/Jun. 2008.
- [4] C. L. Chen, Y.Wang, J.S.Lai, Y.S.Lee, and D. Martin, "Design of parallel inverters for smooth mode transfer microgrid applications," IEEE trans. Power Eletron., vol. 25, no.1 pp. 6-15, Jan.2010.
- [5] C.T. Pan, C.M. Lai, and M. C. Cheng, " A novel high step-up ratio inverters for distributed energy resources(DERs)," in proc. IEEE Int. Power Electron Conf., 2010, pp. 1433-1437.
- [6] C. T. Pan, C. M. Lai, and M.C. Cheng, "A novel integrated single phase inverter with an auxiliary step-up circuit for low-voltage alternative energy source application," IEEE Trans. Power Electron., vol.25. no.9, pp.2234-2241, Sep.2010.
- [7] D.G. Infield, P.Onions, A.D.Simmons, and G.A.smith, "Power quality from multiple grid-connected single-phase inverters," IEEE Trans. Power Del., vol 19, no.4,pp.1983-1989, oct.2004

- [8] S.B.Kjaer, J.K.Pedersen, and F.Blaabjerg,"A review of single-phase grid-connected inverters for photovoltaic modules," IEEE Trans. Ind. Appl., vol. 41, no. 5, pp. 1292-1306, Sep/Oct.2005.
- [9] O.Lopez, R.Teodoresuc, and J. Doval-Gandoy, "Multilevel transformerless topologies for single-phase grid-connected converters,"in proc. IEEE Ind. Electron. Conf., 2006,pp.5191-5196.
- [10] T. Kerekes, R.Teodorescu, and U. Borup, "Transformerless photovoltaic inverters connected to the grid," in Proc. IEEE Appl. Power Electron. Conf., 2007, p.1733-1737
- [11] F. Blaabjerg, Z. Chen, and S. B. Kjaer, "Power electronics as efficiency interface in dispersed power generation systems," IEEE Trans. Power Electron., vol 19, no.5,pp.1184-1194, oct.2004.
- [12] Yi-Hung Liao and Ching-Ming Lai, " Newly constructed simplified single phase multistring multilevel inverter topology for distributed energy resources," in IEEE Trans. Power Electron., vol.26, no.9, Sep. 2011.



**First Author: D.Goutham Krishna,**

Pursuing his M.Tech (EPS) from Anurag Engineering College, Kodad, and completed his B.Tech from Anurag Engineering College, Kodad in 2013.



**Second Author: T.Raghu** completed his

B.Tech and M.Tech in power electronics From JNTUH, Hyderabad. Presently he is working as associate professor, Department of EEE in Anurag Engineering College .his interested areas are research in power electronics applications in power systems, electrical machines, FACTS & HVDC applications.



**Third Author: S.ChandraSekhar** received

his B.Tech Degree in Electrical & Electronics Engineering from RVR&JC college of Engineering; GUNTUR in 2001, M.Tech (High Voltage Engineering) degree in Electrical and Electronics Engineering from University College of Engineering, JNTU, Kakinada in 2004.He is pursuing Ph.D at K L University. Presently he is working as associate professor and Head of the Department of EEE in Anurag Engineering College. He has publications in Eight international journals. He is guiding both undergraduate and post graduate student projects. His area of interest includes Micro Grids, High voltage transmission and Power Systems.